



# EUROSTYL

① LE CORNICI IN POLISTIRENE ESPANSO

② EXPANDED POLYSTYRENE MOULDINGS

③ ZIERPROFILE AUS FORMGESCHÄUMTEM POLYSTYROL

④ CORNICHES EN POLYSTYRÈNE EXPANSÉ

# BOVELACCI



AMERICANSTYL A119W  
EUROSTYL EC00, LPVL  
CLASSICSTYL CA3010L, C3010  
ITALSTYL IA745L, 745

**BOVELACCI**



# BOVELACCI

## EUROSTYL

-  LE CORNICI IN POLISTIRENE ESPANSO
-  EXPANDED POLYSTYRENE MOULDINGS
-  ZIERPROFILE AUS FORMGESCHÄUMTEM POLYSTYROL
-  CORNICHES EN POLYSTYRÈNE EXPANSÉ
-  MOLDURAS DECORATIVAS EXPANDIDAS
-  SANCAS EXPANDIDAS
-  PS-GEËXPANDEERD SIERPROFIELEN
-  ΚΟΡΝΙΖΕΣ ΔΙΟΓΚΩΜΕΝΗΣ ΠΟΛΥΣΤΕΡΙΝΗΣ
-  DESENLI POLISTREN KARTONPIYER
-  EXPANDERADE POLYSTYREN LISTER
-  STUKKATURLISTER I POLYSTYRENE
-  STUKLISTER AF EKSPANDERET POLYSTYREN
-  STYROKSILISTAT
-  EKSPANDIRANE OKRASNE PROFILE IZ POLISTIRENA
-  EKSPANDIRANI POLISTIREN PROFILI
-  ПЛИНТУСА ЭКСПАНДИРОВАННЫЕ
-  LISTWY EKSPANDOWANE
-  LIŠTY POLYSTYREN EXPADOVANÝ
-  CORNISE DIN POLISTIREN EXPANS
-  EXPANDÁLT DÍSZLÉCEK
-  ПЛІНТУС ЕКПАНДОВАНИНЬ
-  ЕКСПАНДИРАНИ ПРОФИЛИ
-  聚苯乙烯泡沫体的装饰
-  発砲スチロール製飾り縁

CORNICI IN POLISTIRENE ESPANSO - CLASSE 1  
EXPANDED PS MOULDINGS - CLASS B1

**BOVELACCI**

①

**LE CORNICI  
PER SOFFITTI**

Cornici in polistirene  
espanso

Polistirene autoestinguente  
Classe 1  
Lunghezza: 1,25 ml per asta

Ⓒ

**CEILINGS  
MOULDINGS**

Expanded polystyrene  
mouldings

Self extinguishing polystyrene  
Class B1  
Length: 1,25 lm (49 1/4")

Ⓓ

**ECKLEISTEN**

Zierprofile aus  
Formgeschäumtem Polystyrol

Schwerentflammbar  
B1 DIN 4102  
Länge: 1,25 Meter

Ⓕ

**CORNICHES  
POUR PLAFOND**

Corniches en polystyrène  
expansé

Polystyrène auto-extinguible  
Classe 1  
Longueur: 1,25 mètres

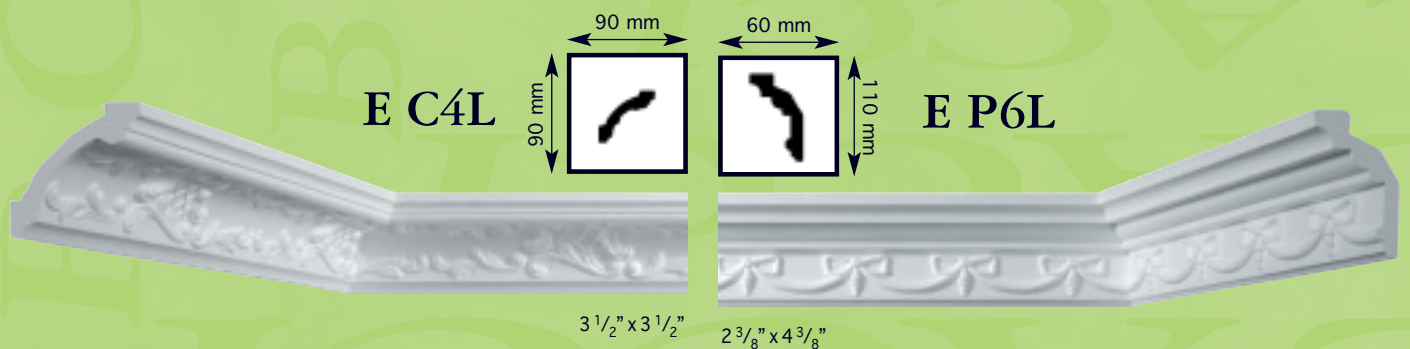
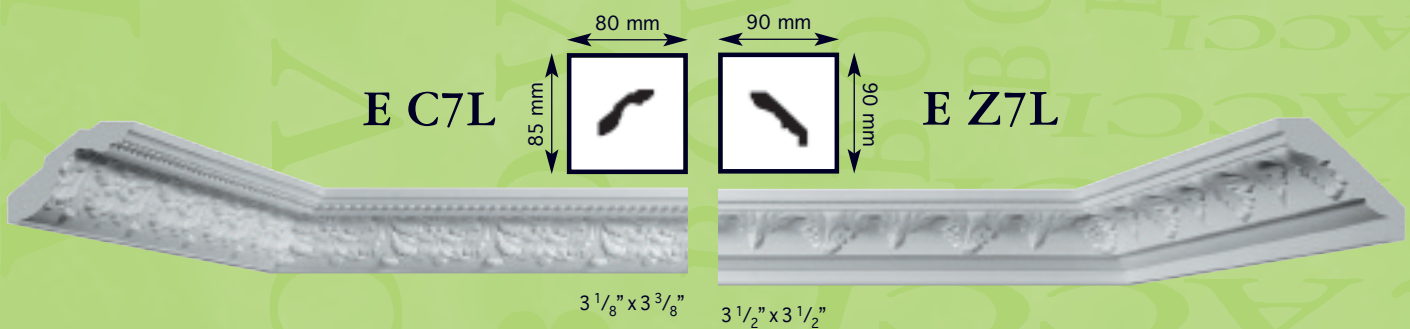
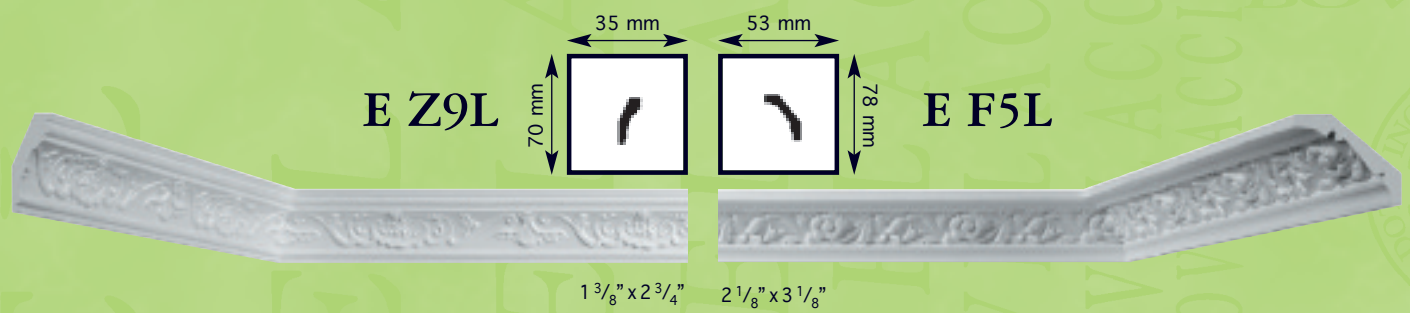
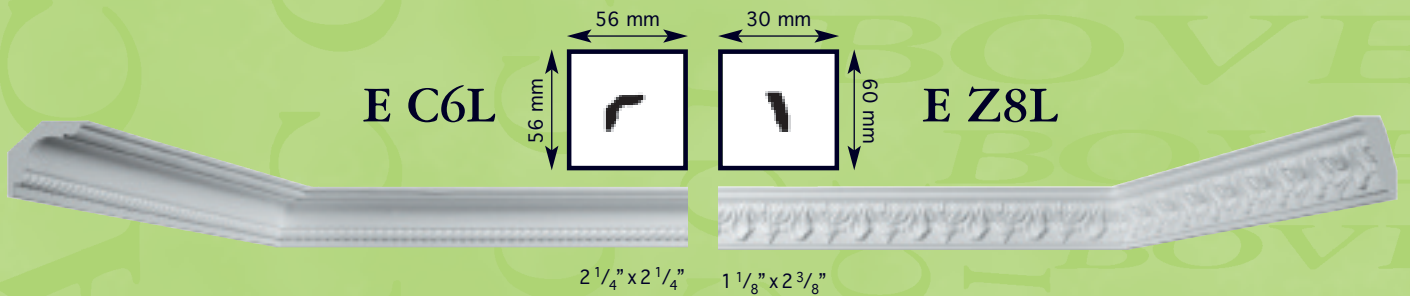

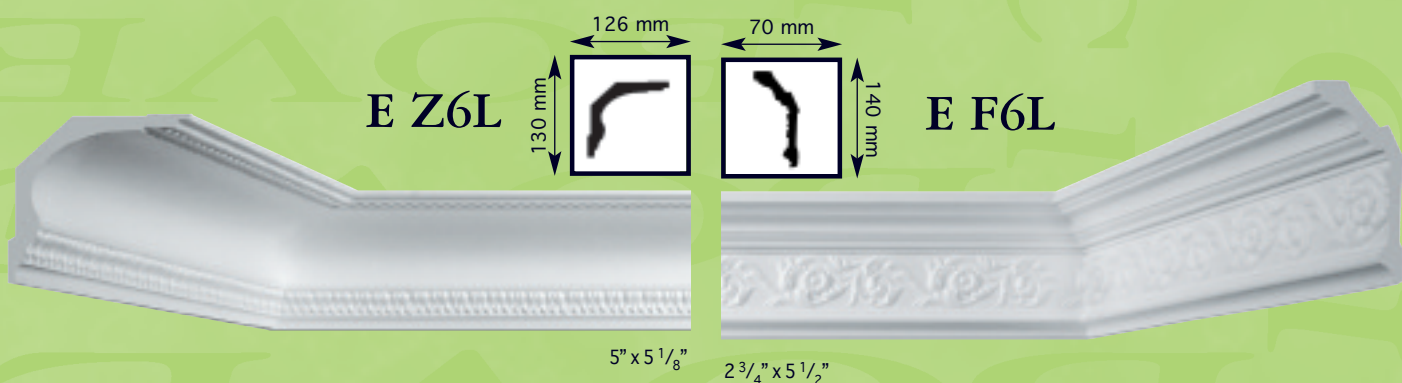
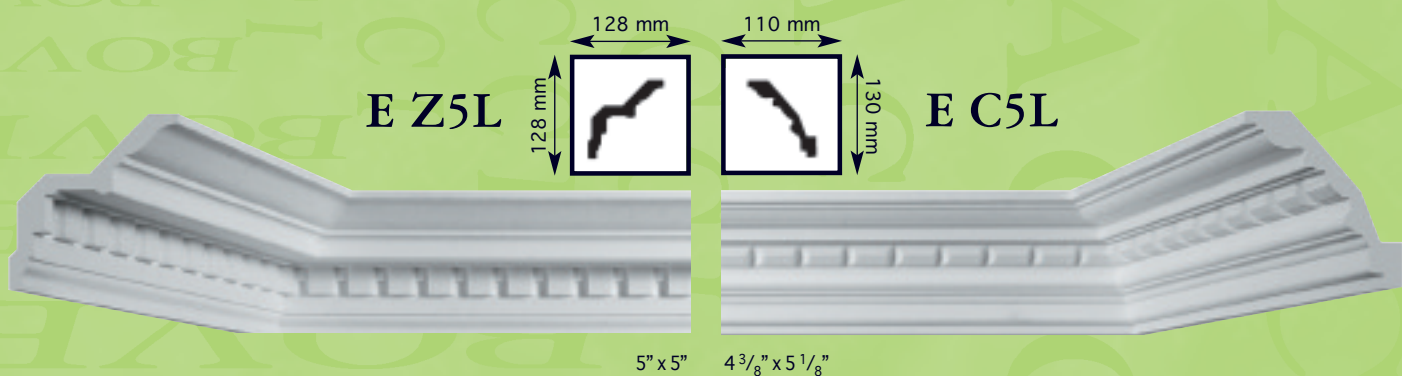
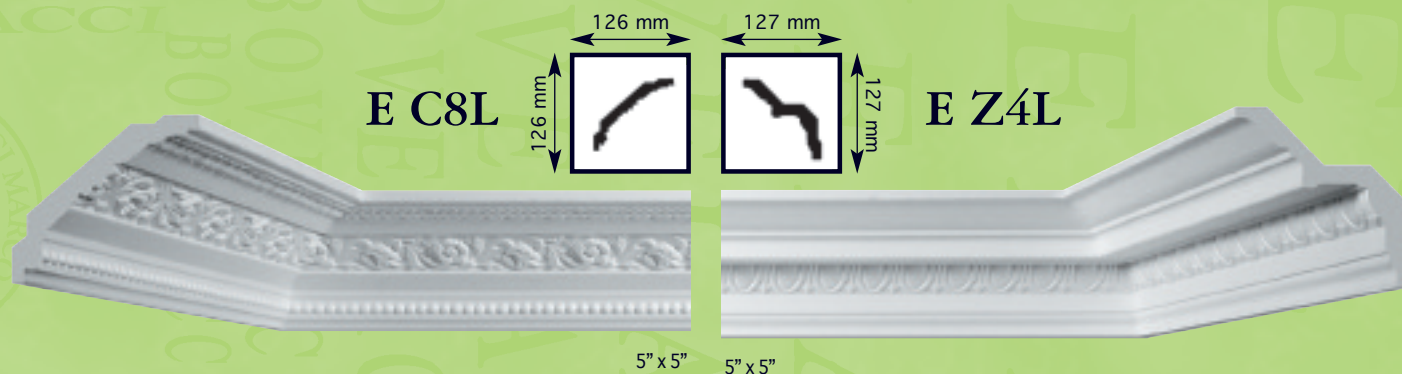
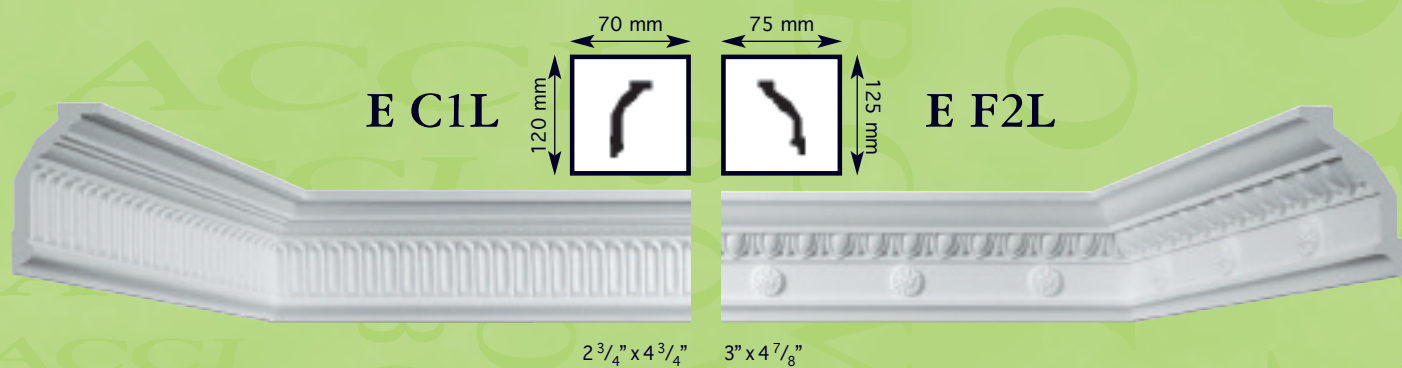
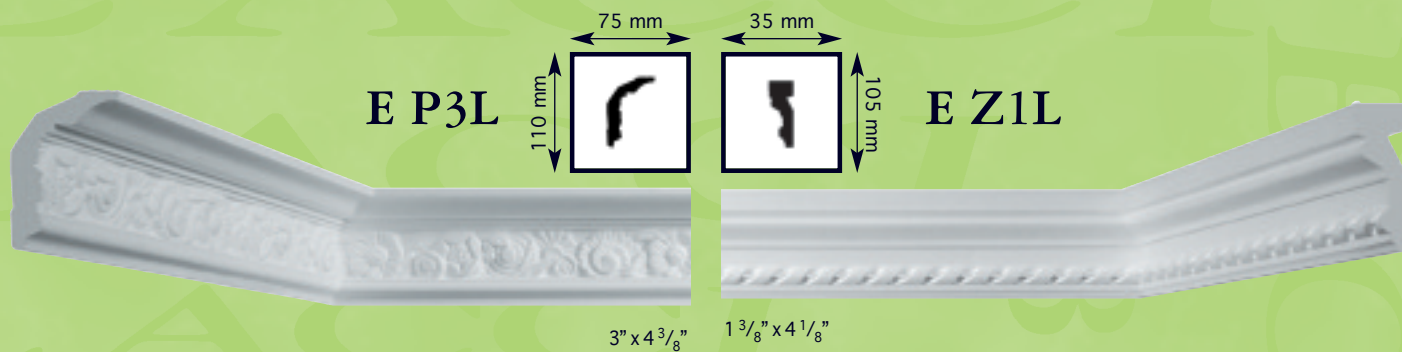

①

Polistirene autoestinguente  
Classe 1  
Lunghezza: 1,25 ml per asta

Ⓒ

Self extinguishing polystyrene  
Class B1  
Length: 1,25 lm (49 1/4")

Ⓓ

Schwerentflammbar  
B1 DIN 4102  
Länge: 1,25 Meter

Ⓕ

Polystyrène auto-extinguible  
Classe 1  
Longueur: 1,25 mètres



**E F8L**

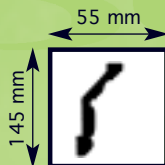

2 1/4" x 5 3/4"



**E P8L**



4 7/8" x 5 1/2"



**E P7L**

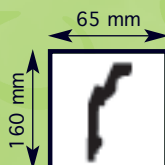

2 1/2" x 6 1/4"



**E F7L**



5 7/8" x 5 7/8"



**E P9L**

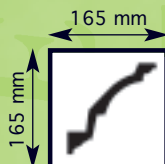

6 1/2" x 6 1/2"



**E C9L**



6 1/8" x 6 1/4"



**E F3L**

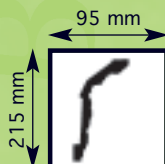

3 3/4" x 8 1/2"



**E F4L**



5 3/4" x 8 1/8"

①  
**LE CORNICI  
ED I NASI  
PER SOFFITTI**

Nasi:  
Angolari Interni  
Angolari esterni  
Polistirene autoestinguente  
Classe 1  
Lunghezza: 1,25 ml per asta

Ⓒ  
**CEILINGS  
MOULDINGS  
AND CORNERS**

Corner blocks:  
Inside corner blocks  
Outside corner blocks  
Self extinguishing polystyrene  
Class B1  
Length: 1,25 lm (49 1/4")

Ⓓ  
**WANDLEISTEN  
UND ECKEN**

Ecken:  
Innenecke  
Aussenecke  
Schwerentflammbar  
B1 DIN 4102  
Länge: 1,25 Meter

Ⓕ  
**CORNICHES  
ET ANGLES  
POUR PLAFOND**

Angles:  
Angles entrants  
Angles sortants  
Polystyrène auto-extinguible  
Classe 1  
Longueur: 1,25 mètres

ENP4LI



ENP4LE



ENP5LI



ENP5LE



ENR1LI



ENR1LE



ENZ2LI



ENZ2LE



ENZ3LI



ENZ3LE

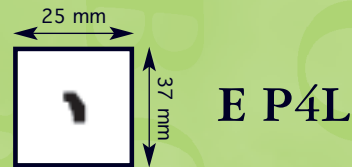

E P4L

1" x 1 1/2"

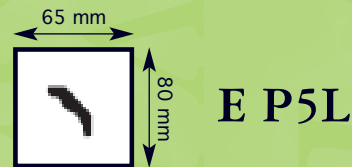

E P5L

2 1/2" x 3 1/8"

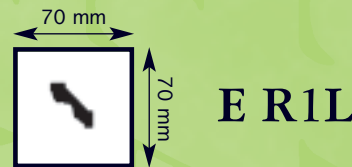

E R1L

2 3/4" x 2 3/4"

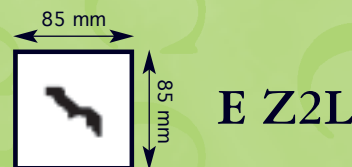

E Z2L

3 3/8" x 3 3/8"

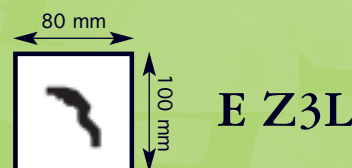

E Z3L

3 1/8" x 3 7/8"

**LE CORNICI E  
GLI ANGOLI PER  
PARETI E SOFFITTI**

Polistirene autoestinguente  
Classe 1  
Lunghezza: 1,25 ml per asta

**PANEL  
MOULDINGS  
AND CORNERS**

Self extinguishing polystyrene  
Class B1  
Length: 1,25 lm (49 1/4")

**WANDLEISTEN  
UND BÖGEN**

Schwerentflammbar  
B1 DIN 4102  
Länge: 1,25 Meter

**CORNICHES ET  
ANGLES POUR  
MURS ET PLAFONDS**

Polystyrène auto-extinguible  
Classe 1  
Longueur: 1,25 mètres

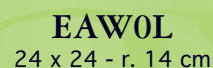
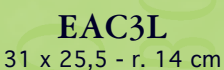



**EAW1L**  
23 x 23 - r. 14 cm



(9" x 9" - r. 5 1/2")

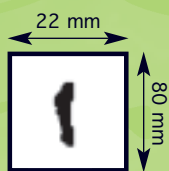

**E W1L**



3 1/8" x 7/8"

**EAW2L**  
24 x 24 - r. 14 cm



(9 1/2" x 9 1/2" - r. 5 1/2")

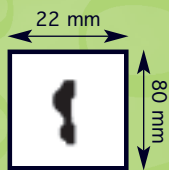

**E W2L**



3 1/8" x 7/8"

**EAW4L**  
30 x 30 - r. 14 cm



(11 3/4" x 11 3/4" - r. 5 1/2")

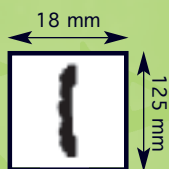

**E W4L**



4 7/8" x 3/4"

**EAW5L**  
26 x 26 - r. 13 cm



(10 1/4" x 10 1/4" - r. 5 1/8")

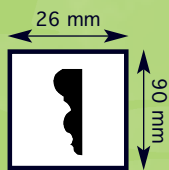

**E W5L**



3 1/2" x 1"



**EAW7L**  
26 x 26 - r. 13 cm

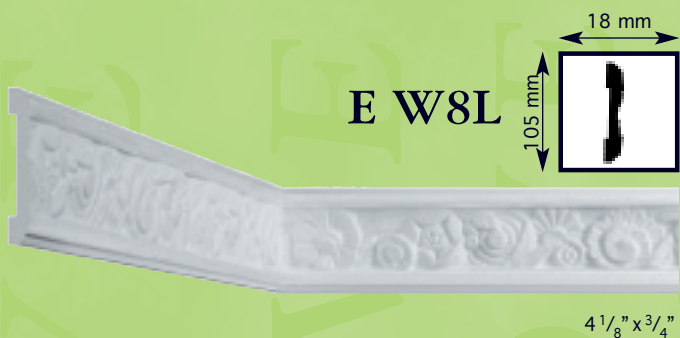
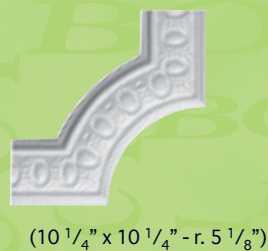

**EAW8L**  
28 x 28 - r. 14 cm



①

I NASI UNIVERSALI  
PER SOFFITTI

ⒼⒷ

UNIVERSAL  
CORNER BLOCKS

Ⓓ

UNIVERSELLE  
ECKEN

Ⓕ

ANGLES UNIVERSELS  
POUR PLAFOND

mm 30x30



dim=mm 30x30 L=cm 4x4

**ENLP30I**



dim=mm 30x30 L=cm 3,5

**ENLP30C**



dim=mm 30x30 L=cm 4x4

**ENLP30E**



dim=mm 30x30 L=cm 4x4

**ENDP30I**



dim=mm 30x30 L=cm 3,5

**ENDP30C**



dim=mm 30x30 L=cm 4x4

**ENDP30E**

consigliati per cornici Eurostyl:

for Eurostyl mouldings:

für Eckleisten Eurostyl:

pour corniches Eurostyl:

mm 50x50: P4L



dim=mm 50x50 L=cm 7x7

**ENLM50I**



dim=mm 50x50 L=cm 5,5

**ENLM50C**



dim=mm 50x50 L=cm 7x7

**ENLM50E**



dim=mm 50x50 L=cm 7x7

**ENDM50I**



dim=mm 50x50 L=cm 5,5

**ENDM50C**



dim=mm 50x50 L=cm 7x7

**ENDM50E**

consigliati per cornici Eurostyl:

for Eurostyl mouldings:

für Eckleisten Eurostyl:

pour corniches Eurostyl:

mm 80x80: C6L, F5L, P5L, R1L, Z8L, Z9L



dim=mm 80x80 L=cm 10,5x10,5

**ENLG80I**



dim=mm 80x80 L=cm 8,5

**ENLG80C**



dim=mm 80x80 L=cm 10,5x10,5

**ENLG80E**



dim=mm 80x80 L=cm 10,5x10,5

**ENDG80I**



dim=mm 80x80 L=cm 8,5

**ENDG80C**



dim=mm 80x80 L=cm 10,5x10,5

**ENDG80E**

consigliati per cornici Eurostyl:

for Eurostyl mouldings:

für Eckleisten Eurostyl:

pour corniches Eurostyl:

mm 110x110: C1L, C4L, P3L, P6L, Z2L, Z3L, Z9L, C7L



dim=mm 110x110 L=cm 13,5x13,5

**ENLXG110I**

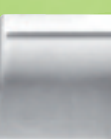

dim=mm 110x110 L=cm 11,5

**ENLXG110C**



dim=mm 110x110 L=cm 13,5x13,5

**ENLXG110E**



dim=mm 110x110 L=cm 13,5x13,5

**ENDXG110I**



dim=mm 110x110 L=cm 11,5

**ENDXG110C**



dim=mm 110x110 L=cm 13,5x13,5

**ENDXG110E**



# EUROSTYL

-  I ROSONI
-  CEILING CENTERS
-  ROSETTEN
-  ROSACES POUR PLAFONDS
-  ROSETONES
-  ROSETAS PARA TETO
-  ROZETTEN
-  ΚΟΡΝΙΖΕΣ ΔΙΟΓΚΟΜΕΝΗΣ ΠΟΛΥΣΤΕΡΙΝΗΣ
-  TAVAN GÖBEKLERİ
-  TAKROSETTER
-  ROSETTER
-  ROSETTER
-  ROSETIT
-  ROZETE
-  ROZETA
-  РОЗЕТКИ ДЛЯ ПОТОЛКА
-  ROZETY
-  ROZETY
-  ROZETA PENTRU TAVANURI
-  ROZETTÁK
-  РОЗЕТКИ ДЛЯ СТЕЛІ
-  РОЗЕТКИ ЗА ТАВАН
-  天花
-  発砲スチロール製バラ窓

POLISTIRENE ESPANSO - CLASSE 1  
EXPANDED POLYSTYRENE - CLASS B1



**E C00**  
ø 6,5 cm  
(2 1/2")



**E B2L**  
ø 12 cm  
(4 3/4")



**E B13**  
9 x 9 cm  
(3 1/2" x 3 1/2")



**E R03L**  
ø 15,5 cm  
(6 1/8")



**E R9**  
ø 9,5 cm  
(3 3/4")



**E B1L**  
ø 15 cm  
(5 7/8")



**E R16**  
ø 16 cm  
(6 1/4")



**E R21**  
ø 21 cm  
(7 7/8")



**E S1**  
ø 22 cm  
(8 5/8")



**E R19**  
ø 19 cm  
(7 1/2")



**E C21**  
ø 24 cm  
(9 1/2")



**E B21**  
ø 28 cm  
(11")



**E R25**  
ø 25 cm  
(9 7/8")



**E R29**  
ø 29 cm  
(11 3/8")



**E M51**  
ø 30 cm  
(11 3/4")



**E R31**  
ø 31 cm  
(12 1/4")



**E R32**  
 ø 32 cm  
 (12 <sup>5</sup>/<sub>8</sub>"



**E C22**  
 ø 33 cm  
 (13"



**E R33**  
 ø 33 cm  
 (13"



**E B24**  
 ø 34 cm  
 (13 <sup>3</sup>/<sub>8</sub>"



**E R38**  
 ø 38 cm  
 (15"



**E R40**  
 ø 40 cm  
 (15 <sup>3</sup>/<sub>4</sub>"



**E R6**  
 ø 41 cm  
 (16 <sup>1</sup>/<sub>8</sub>"



**E R41**  
 ø 41 cm  
 (16 <sup>1</sup>/<sub>8</sub>"



**E C15**  
 ø 41 cm  
 (16 <sup>1</sup>/<sub>8</sub>"



**E R43**  
 43 x 30 cm  
 (16 <sup>7</sup>/<sub>8</sub>" x 11 <sup>3</sup>/<sub>4</sub>"



**E R42**  
 ø 42 cm  
 (16 <sup>1</sup>/<sub>2</sub>"



**E R44**  
 ø 44 cm  
 (17 <sup>3</sup>/<sub>8</sub>"



**E C25**  
ø 44 cm  
(17 <sup>3</sup>/<sub>8</sub>"



**E M52**  
ø 45 cm  
(17 <sup>3</sup>/<sub>4</sub>"



**E R45**  
ø 45 cm  
(17 <sup>3</sup>/<sub>4</sub>"



**E R48**  
ø 48 cm  
(19"



**E C33**  
ø 47 cm  
(18 <sup>1</sup>/<sub>2</sub>"



**E R49**  
ø 49 cm  
(19 <sup>1</sup>/<sub>4</sub>"



**E O1**  
53 x 43 cm  
(20 <sup>7</sup>/<sub>8</sub>" x 16 <sup>7</sup>/<sub>8</sub>"



**E R50**  
ø 50 cm  
(19 <sup>5</sup>/<sub>8</sub>"



DECORKIT  
ROSONI



**E R51**  
ø 51 cm  
(20 <sup>1</sup>/<sub>8</sub>"



**E R53**

ø 53 cm

(20 7/8")



**E R55**

ø 55 cm

(21 5/8")



**E R60**

ø 60 cm

(23 5/8")



**E R61**

ø 61 cm

(24")



**E R64**

ø 64 cm

(25 1/4")



**E C27**

ø 66 cm

(26")

①

**IL ROSONE  
COMPONIBILE R52**



**E R52**  
Ø 52 cm  
(20 1/8")

②

**COMPOSING  
CEILING CENTRE R52**



**E RF 803/52 DG**  
L.43 x p.3,5 x H.36 cm  
(1/4 di cerchio Ø 52 cm)  
(L. 16 15/16" x d. 1 6/16" x H. 14 3/16")

③

**ROSETTE R52 UND  
ZUBEHÖR**



**E RF 803/52 DP**  
L.43 x p.4 x H.23,5 cm  
(1/4 di cerchio Ø 52 cm)  
(L. 16 15/16" x d. 1 9/16" x H. 9 4/16")

④

**ROSACES  
À COMPOSER R52**



**E RF 803/52 L**  
L.40 x H.10 cm  
(1/4 di cerchio Ø 52 cm)  
(L. 15 12/16" x H. 3 15/16")

Esempi di realizzazione:

Examples of realization:

Verarbeitungsbeispiele:

Exemple de réalisation:



**E R52 +  
2 x E RF803/52 DG  
2 x E RF803/52 DP**



**E R52 +  
4 x E RF803/52 DG**



**E R52 +  
4 x E RF803/52 DP**



**2 x E RF803/52 DG +  
2 x E RF803/52L**



①

LE MENSOLE  
PER PARETI**E M23L**L.11 x p.6,5 x H.14,5 cm  
(L. 4<sup>3</sup>/<sub>8</sub>" x d. 2<sup>1</sup>/<sub>2</sub>" x H. 5<sup>3</sup>/<sub>4</sub>" )

Ⓒ

CORBELS  
FOR WALLS**E M11L**L.11,5 x p.7 x H.17 cm  
(L. 4<sup>1</sup>/<sub>2</sub>" x d. 2<sup>3</sup>/<sub>4</sub>" x H. 6<sup>3</sup>/<sub>4</sub>" )

Ⓓ

WANDKONSOLEN

Ⓕ

CORBEAUX  
POUR MURS**E M19L**L.15,5 x p.7 x H.19 cm  
(L. 6<sup>1</sup>/<sub>8</sub>" x d. 2<sup>3</sup>/<sub>4</sub>" x H. 7<sup>1</sup>/<sub>2</sub>" )**E M03L**L.19,5 x p.10 x H.20 cm  
(L. 7<sup>5</sup>/<sub>8</sub>" x d. 3<sup>7</sup>/<sub>8</sub>" x H. 7<sup>7</sup>/<sub>8</sub>" )**E M62L**L.17 x p.12 x H.26 cm  
(L. 6<sup>3</sup>/<sub>4</sub>" x d. 4<sup>3</sup>/<sub>4</sub>" x H. 10<sup>1</sup>/<sub>4</sub>" )**E M25L**L.20 x p.11 x H.32 cm  
(L. 7<sup>7</sup>/<sub>8</sub>" x d. 4<sup>3</sup>/<sub>4</sub>" x H. 12<sup>5</sup>/<sub>8</sub>" )LE MENSOLE  
PER ANGOLICORBELS  
FOR ANGLES

ECKKONSOLEN

CORBEAUX  
POUR ANGLES**E MA12L**L.18 x r.12,5 x H.17 cm  
(L. 7<sup>1</sup>/<sub>8</sub>" x r. 4<sup>7</sup>/<sub>8</sub>" x H. 6<sup>3</sup>/<sub>4</sub>" )**E MA18L**L.25 x r.18 x H.15 cm  
(L. 9<sup>7</sup>/<sub>8</sub>" x r. 7<sup>1</sup>/<sub>8</sub>" x H. 5<sup>7</sup>/<sub>8</sub>" )

①

**I FREGI**



**O NA1L**

L.12,5 x p.4 x H.9 cm  
(L.4 7/8" x d.1 5/8" x H.3 1/2")

Ⓒ

**DECORATIONS**



**O NA2L**

L.20 x p.5 x H.10 cm  
(L.7 7/8" x d.2" x H.3 7/8")

Ⓓ

**FRIESE**



**E F21L**

L.14 x p.3 x H.8,5 cm  
(L.5 1/2" x d.1 1/8" x H.3 3/8")

Ⓕ

**FRIESES**



**E F36L**

L.11,7 x p.4 x H.16 cm  
(L.4 5/8" x d.1 5/8" x H.6 1/4")



**E F54L**

L.12,7 x p.3 x H.12,8 cm  
(L.5" x d.1 1/8" x H.5")



**E F24L**

L.16 x p.5 x H.26 cm  
(L.6 1/4" x d.2" x H.10 1/4")



**E P02L**

L.32 x p.8 x H.22 cm  
(L.12 5/8" x d.3 1/8" x H.8 5/8")



**O SLG**

**SOLE E LUNA GRANDE**  
Ø 39 cm (Ø 15")

**LE ISTRUZIONI DI MONTAGGIO**

**INSTALLATION INSTRUCTIONS**

**VERARBEITUNGSTIPS**

**INSTRUCTION DE MONTAGE**



1. Praticare col cutter un foro centrale nel rosone se è prevista l'applicazione di un lampadario.  
2. Applicare la speciale colla Eurocoll lungo la circonferenza.  
3. Appoggiare il rosone al soffitto nel punto desiderato. Verniciare con idropittura.

1. Make a central hole in the middle of the ceiling centre by using a cutter.  
2. Apply the special Eurocoll glue around the circumference.  
3. Lean the centre on the ceiling. Apply water-based paint.

1. Um eine Öffnung für ein Lampenkabel zu erhalten, wird die passende Größe mit einem Cutter herausgeschnitten.  
2. Ausreichend Eurocoll-Kleber am Rand der Rosette auftragen.  
3. Die Rosette passgenau ansetzen und vorsichtig andrücken. Nach ausreichender Trocknung des Klebers kann die Rosette gestrichen werden.

1. Percer un trou au milieu de la rosace à l'aide d'un cutter.  
2. Appliquer la colle spéciale Eurocoll à la circonférence.  
3. Plaquer la rosace au plafond et peindre avec une peinture acrylique.

I

**LE COLONNE**

Le colonne in polistirolo espanso possono essere tinteggiate con vernici a base d'acqua

Alta densità (kg. 50/m<sup>3</sup>)  
Componibili; non portanti



**O 35SL**  
COLONNA  
CORINZIA LISCIA  
H. 80 cm  
(31 1/2")



**O 40IL**  
COLONNA  
IONICA LISCIA  
H. 70 cm  
(27 1/2")

GB

**COLUMNS**

Our expanded polystyrene columns may be decorated with water-based paints

High density (kg. 50/m<sup>3</sup>)  
Modular; not supporting



D

**SÄULEN**

Die Säulen sind mit Dispersionsfarbe oder Acryllack überstreichbar

Hohes Raumgewicht (kg. 50/m<sup>3</sup>)  
Zusammensetzbar; nicht tragend

F

**COLONNES**

Nos colonnes en polystyrène expansé doivent être décorées avec de la peinture acrylique









Haute densité (kg. 50/m<sup>3</sup>)  
Composable; non porteuse



**O 36SR**  
COLONNA  
CORINZIA RIGATA  
H. 80 cm  
(31 1/2")



**O 39IR**  
COLONNA  
IONICA RIGATA  
H. 70 cm  
(27 1/2")

ARTICOLO	DESCRIZIONE
 35 SL	Colonna standard liscia corinzia 35 x 35 x h 80 cm Standard smoothed corinthian column (13 3/4" x 13 3/4" x h 31 1/2")
 36 SR	Colonna standard rigata corinzia 35 x 35 x h 80 cm Standard fluted corinthian column (13 3/4" x 13 3/4" x h 31 1/2")
 40 IL	Colonna standard liscia ionica 41 x 41 x h 70 cm Standard smoothed ionic column (16 1/8" x 16 1/8" x h 27 1/2")
 39 IR	Colonna standard rigata ionica 41 x 41 x h 70 cm Standard fluted ionic column (16 1/8" x 16 1/8" x h 27 1/2")
 31 BA	Base 35 x 35 x h 23 cm (13 3/4" x 13 3/4" x 9")
 32 CA	Capitello corinzio 35 x 35 x h 27 cm Corinthian capital (13 3/4" x 13 3/4" x 10 5/8")
 38 CI	Capitello ionico 41 x 41 x h 17 cm Ionic capital (16 1/8" x 16 1/8" x 6 3/4")
 34 RT	Troncorigato h 30 cm ø 22,5 cm Fluted pillar (h 11 3/4" x ø 8 7/8")
 33 LT	Troncoliscio h 30 cm ø 22,5 cm Smoothed pillar (h 11 3/4" x ø 8 7/8")



①

**LE LESENE**

Componibili; non portanti



**EL01P**

**LESENA PICCOLA**  
H. 313 cm (123 1/4")

(EL01CP, 2xEL01TTP,  
2xEL01TP, EL01BP)

Ⓒ

**PILASTERS**

Modular; not supporting

**EL01CP**

**Capitello lesena piccola**  
L. 17,5 x p. 5,5 - H. 17 cm

*Capitel small pilaster*  
(L. 6 7/8" x d. 2 1/8" - H. 6 3/4")



**EL01TTP**

**Terminale tronco lesena piccola**  
L. 11,5 x p. 2,5 - H. 10 cm

*Pillar end, small pilaster*  
(L. 4 1/2" x d. 1" - H. 3 7/8")



**EL01TP**

**Tronco lesena piccola**  
L. 11,5 x p. 2,5 - H. 125 cm

*Pillar small pilaster*  
(L. 4 1/2" x d. 1" - H. 49 1/4")



**EL01TTP**

**Terminale tronco lesena piccola**  
L. 11,5 x p. 2,5 - H. 10 cm

*Pillar end, small pilaster*  
(L. 4 1/2" x d. 1" - H. 3 7/8")



**EL01BP**

**Base lesena piccola**  
L. 11,5 x p. 3,5 - H. 26 cm

*Base small pilaster*  
(L. 4 1/2" x d. 1 3/8" - H. 10 1/4")



Ⓓ

**PILASTER**

Zusammensetzbar; nicht tragend

**EL02CG**

**Capitello lesena grande**  
L. 21,5 x p. 6,5 - H. 17 cm

*Capitel big pilaster*  
(L. 8 1/2" x d. 2 1/2" - H. 6 3/4")



**EL02TTG**

**Terminale tronco lesena grande**  
L. 14 x p. 2,5 - H. 10 cm

*Pillar end, big pilaster*  
(L. 5 1/2" x d. 1" - H. 3 7/8")



**EL02TG**

**Tronco lesena grande**  
L. 14 x p. 2,5 - H. 125 cm

*Pillar big pilaster*  
(L. 5 1/2" x d. 1" - H. 49 1/4")



**EL02TTG**

**Terminale tronco lesena grande**  
L. 14 x p. 2,5 - H. 10 cm

*Pillar end, big pilaster*  
(L. 5 1/2" x d. 1" - H. 3 7/8")



**EL02BG**

**Base lesena grande**  
L. 14 x p. 3,5 - H. 26 cm

*Base big pilaster*  
(L. 5 1/2" x d. 1 3/8" - H. 10 1/4")



Ⓕ

**PILASTRES**

Composable; non porteuse

**EL02G**

**LESENA GRANDE**  
H. 313 cm (123 1/4")

(EL02CG, 2xEL02TTG,  
2xEL02TG, EL02BG)



**LE ISTRUZIONI DI MONTAGGIO**

1. Assemblare le colonne secondo la composizione preferita ed incollate i componenti con Eurocoll
2. Dopo una settimana stuccate le giunture con lo stesso collante utilizzando una normale spatola
3. Rimuovere quindi la colla in eccesso con una spugna bagnata

**INSTALLATION INSTRUCTIONS**

1. Compose columns according to your favourite combination and fix components with Eurocoll.
2. After a week fill all joints and gaps with the same adhesive.
3. Wipe off excess glue with a clean damp sponge.

**VERARBEITUNGSTIPS**

1. Nachdem Sie sich für eine Säulenkombination entschieden haben, fixieren sie diese mit Eurocoll-Kleber.
2. Nach einer Woche verspachteln Sie alle Fugen mit Klebstoff.
3. Wischen Sie den austretenden Kleber mit einem sauberen feuchten Schwamm ab.

**INSTRUCTION DE MONTAGE**

1. Réaliser votre composition de colonne et fixer les différents éléments avec la colle Eurocoll
2. Après une semaine remplir les joints avec la colle Eurocoll
3. Essuyer l'excès de colle à l'aide d'une éponge propre et humide.

① **LE ISTRUZIONI PER IL MONTAGGIO**      ② **ASSEMBLING INSTRUCTIONS**      ③ **VERARBEITUNGSTIPS**      ④ **INSTRUCTION DE MONTAGE**



È preferibile posare le cornici, gli angoli ed i rosoni prima di tappezzare le pareti. I prodotti devono essere applicati su pareti asciutte, pulite e sgrassate.

We suggest to install mouldings, corners and roses before wallpaping. Items must be applied on dry clean and ungreased surfaces.

Wir empfehlen die Zierprofile, Ecken, Rosetten nach Möglichkeit vor den Tapezierarbeiten zu verkleben. Der Untergrund muss saugfähig, sauber, trocken und staubfrei sein.

C'est préférable poser les corniches, angles et les rosaces avant de tapisser les parois. Les produits doivent être appliqués sur parois sèches propres et dégraissées.

Sono sufficienti i seguenti accessori: cassetta per taglio, sega speciale BOVELACCI, Eurocoll, spatola, spugna, pittura, pennelli, cutter e metro.

You need only the following tools: mitre-box, BOVELACCI special saw, glue Eurocoll, spatula, sponge, paint, brush, cutter and metre.

Folgende Werkzeuge werden benötigt: Gehrungslade, BOVELACCI-Spezialsäge, Eurocoll-Klebstoff, Spachtel, Schwamm, Pinsel, Cuttermesser und ein Zollstock.

Les suivants accessoires sont suffisants: caissette pour coupe; scie spécial BOVELACCI; Eurocoll; spatule; éponge; peinture; pinceaux; cutter et mètre.

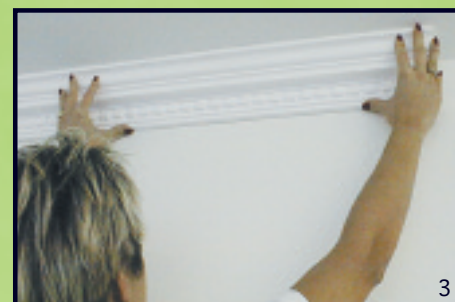
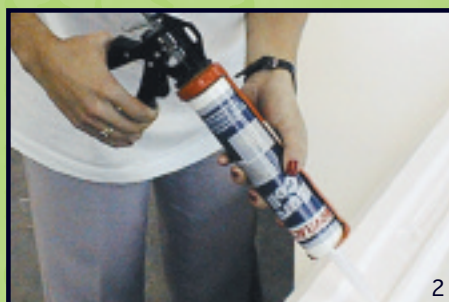

1. Iniziare a tagliare le cornici in modo da realizzare gli angoli che vi servono. Controllate che combino.

1. Cut straight ends to make the type of corners you need. Check fit.

1. Beim Schneiden der Gehrung ist unbedingt darauf zu achten, dass die "Deckenklebefläche" des Zierprofils auf dem Boden und die "Wandklebefläche" an der Innenwand der Gehrungslade liegt.

1. Commencer à couper les corniches et réaliser les angles désirés. Vérifier le point de jonction.

2. Stendere la colla speciale Eurocoll su entrambe le superfici posteriori dell'asta che andranno a contatto con la parete o il soffitto, nonchè fra le giunture (incidenza media: 1 cart. x 10 ml).

2. Apply the special glue Eurocoll on both back surfaces of the stick meant to lean on the wall and inside the joint (average incidence: 1 cart. x 10 ml).

2. Nachdem die Gehrung auf Passgenauigkeit geprüft wurde, wird der Klebstoff auf beide Klebeflächen und im Stoßbereich mit der Kartusche oder mit dem Spachtel aufgetragen (durchschnittlicher Verbrauch: 1 Kart. x 10 ml).

2. Appliquer la colle spéciale Eurocoll sur tous les surfaces postérieures de la corniche au contact avec la paroi ou le plafond et entre les jointures (incidence moyenne: 1 cart. x 10 ml).

3. Applicare la cornice alla parete con una leggera pressione. Dopo una settimana riempite con la colla ogni giuntura o spazio.

3. Press pieces into the corner with a light pressure. After a week fill all joints and gaps with glue.

3. Das Zierprofil passgenau ansetzen und vorsichtig andrücken. Nach einer Woche alle Fugen und Stöße mit Klebstoff füllen.

3. Appliquer la corniche à la paroi avec une légère pression. Après une semaine remplir avec la colle chaque jointure ou espace.

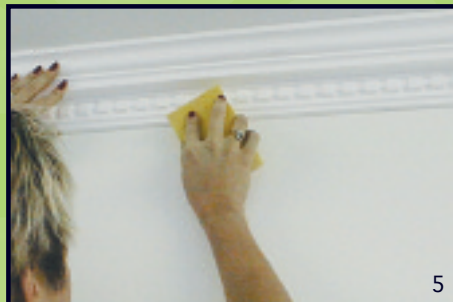

4. Togliete l'eccesso di colla con l'aiuto di una spatola.

5. Pulite quindi con l'aiuto di una spugna.

6. Lasciate asciugare e rifinite con vernice a base d'acqua.

4. Remove glue in excess by using a spatula.

5. Wipe smooth with a clean damp sponge.

6. Let dry and apply water-based paint.

4. Überschüssigen Klebstoff mit einem Spachtel sofort entfernen.

5. Anschließend Klebstoffreste mit einem feuchten Schwamm sofort abwaschen.

6. Die Zierprofile können nach einer Trocknungszeit von ca. 24 Std. mit Dispersionsfarbe oder Acryllack überstrichen werden.

4. Enlever avec une spatule l'excès de colle.

5. Nettoyer avec une éponge.

6. Laisser essuyer et puis peindre avec peinture à base d'eau.

## EUROCOLL



mlt 310 - Kg 7 - Kg 1,8

Collante speciale per polistirene in pasta bianca (incidenza media: 1 cart. x 10 ml)

Temperatura di applicazione: +8 °C ÷ +30 °C

Temperatura d'impiego ad essiccazione avvenuta: +0 °C ÷ +55 °C

Conservazione: 10 mesi

Teme il gelo

Lasciare asciugare per una settimana, poi stuccare con Eurocoll e rifinire con una vernice a base d'acqua

Prima del montaggio si consiglia di testare la colla sul sottofondo

Special adhesive for polystyrene white paste (average incidence: 1 cart. x 10 lm)

Application temperature: +8 °C ÷ +30 °C

Temperature stability +0 °C ÷ +55 °C

Shelf life: 10 months

Keep away from chill

Let dry for a week, before filling up the joints with Eurocoll and finishing with water-based paint

Testing glue before applying is recommended

Spezial-Klebstoff für Polystyrol, weiss, pastös (durchschnittlicher Verbrauch: 1 Kart. x 10 ml)

Verarbeitungstemperatur: +8 °C ÷ +30 °C

Temperaturbeständigkeit: +0 °C ÷ +55 °C

Lagerstabilität: 10 Monate

Nach einer Trocknungszeit von einer Woche können die Fügen mit Eurocoll gefüllt werden und mit Dispersionsfarbe oder Acryllack überstrichen werden

Vor der Montage testen Sie bitte mit einem kl. Musterstück die Festigkeit des Klebers auf dem Untergrund

Colle spéciale pour polystyrène en pâte blanche (incidence moyenne: 1 cart. x 10 ml)

Température d'application: +8°C à +30°C

Température de stabilité: 0°C à +55°C

Durée de conversation: 10 mois

Conserver à l'abri du gel Laissez sécher une semaine avant de remplir les joints de colles et de peindre avec une peinture acrylique

Un test de la colle est recommandé avant son, utilisation

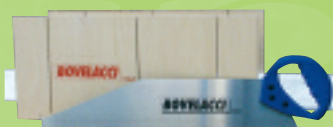

## LA SEGA SPECIALE

L. 50 cm

## LA CASSETTA PER TAGLIO

Dim. int. 16 x 20 x L. 50 cm

## SPECIAL SAW

L. 50 cm

## MITRE-BOX

Dim. int. 16 x 20 x L. 50 cm

## SPEZIALSÄGE

L. 50 cm

## GEHRUNGSLADE

Dim. int. 16 x 20 x L. 50 cm

## SCIE SPÉCIAL

L. 50 cm

## BOITE À ONGLET

Dim. int. 16 x 20 x L. 50 cm



EUROSTYL EF3L, EM62L, CN3002  
I CLASSICI C3010 H.Q. CA3010 H.Q.  
CF3010 H.Q. C3430 H.Q. CF3621 H.Q. CL3210 H.Q.  
CP3512 H.Q. CP3591 H.Q. CP3592 H.Q.  
I PROFILI PER LA CASA PRB110 LEGNO CHIARO

**BOVELACCI**

Dott. Ing. Bovelacci Marco 2003

**E** EUROSTYL



**T** TILESTYL **S** STARSTYL

I PANNELLI PER SOFFITTI  
ED I CONTROSOFFITTI

TILES FOR CEILINGS  
AND FALSE CEILINGS

**I** ITALSTYL **E** EUROSTYL **X** EXTRASTYL

**C** CLASSICSTYL **A** AMERICANSTYL

LE CORNICI, I ROSONI, LE TRAVI,  
GLI ANGOLI ED I FREGI

IN POLISTIRENE ESTRUSO, ESPANSO, POLIMERI ESPANSI,  
POLIURETANO E "POLISTRUTTURATO"

MOULDINGS, CEILING CENTRES, BEAMS,  
CORNER BLOCKS AND DECORS

EXTRUDED AND EXPANDED PS, EXPANDED POLYMERS,  
POLYURETHANE AND "POLISTRUTTURATO"

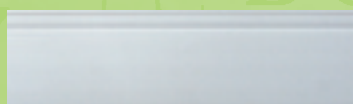

**N** NEWSTYL

I PROFILI IN POLIMERI ESTRUSI  
AD ALTA DENSITÀ

HIGH DENSITY EXTRUDED  
POLYMERS PROFILES



**P** PROFILSTYL

I PROFILI PER LA CASA  
TRIMMINGS

**B** BRICKSTYL

PROFILI PER L'ESTERNO  
EXTERIOR MOULDINGS

**O** OBJECTSTYL

LOGGETTISTICA  
PATCHWORK OBJECTS



I MANICHINI  
MANNEQUINS

**E** EUROSTYL

LE COLONNE  
COLUMNS

**W** WOODSTYL

LE TRAVI IN POLIURETANO  
POLYURETHANE BEAMS

**K** KRISTALSTYL

OGGETTI TRASPARENTI  
TRANSPARENT OBJECTS

**BOVELACCI**



**BOVELACCI**

per carico merci:  
Bovelacci Cargo  
Via Fiume Ronco, 2  
I-47122 Forlì - ITALY

Via del Commercio, 5  
I-47122 Forlì - ITALY  
Tel. +39 0543 811611  
Fax +39 0543 721127

I.P. Ufficio Marketing Bovelacci



8 010971 437073

Le caratteristiche tecniche indicate nel presente catalogo vengono fornite a titolo indicativo e potranno essere modificate senza preavviso. Non devono quindi essere considerate a scopo di specificità. The given values are indicative and can be changed without notice. They cannot be considered like a state.

This leaflet and the designs embodied within are protected by copyright law and international treaties. Unauthorized reproduction of the leaflet or any portion of it or reproduction of any of the designs embodied therein may result in severe civil penalties and will be prosecuted to the maximum. All rights reserved, Bovelacci Forlì Italy.